

SLOANLED

THINLED CONSTANT CURRENT INSTALLATION GUIDE

Product covered in this guide:

ThinLED CC:	<u>Part Number</u>	<u>Description</u>
	701228-18-A	Amber ThinLED Constant Current
	701228-18-B	Blue ThinLED Constant Current
	701228-18-G	Green ThinLED Constant Current
	701228-18-R	Red ThinLED Constant Current
	701228-18-W	White ThinLED Constant Current
	701228-18-Y	Yellow ThinLED Constant Current

SloanLED **(888) 747-4LED** **www.SloanLED.com**

Attention!

Scope: This procedure is designed to aid in the installation of SloanLED's ThinLED Constant Current channel letter illumination product.

Skilled tradespersons that are familiar with general construction, electrical and sign installation techniques should do the installation.

Licensed electricians should provide all installation and hook-up of both the primary input and secondary outputs of the Power Supply.

All installation and hook-up should be done in accordance with all national and local codes.

In no way is this document intended to construe warranty or fitness of use of the products described, nor is it intended to provide safety instruction for those installing the product.

**THE FIELD ASSEMBLY OF THIS SECTIONAL SIGN IS SUBJECT TO THE ACCEPTANCE OF LOCAL INSPECTION AUTHORITY.
LES ENSEIGNES MODULAIRES MONTEES SUR PLACE PEUVENT ETRE VERIFIEES EN TOUT TEMPS PAR LE SERVICE D'INSPECTION LOCAL.**

CAUTION: TURN OFF ALL INTEGRAL DISCONNECTS BEFORE SERVICING (IF INTEGRAL DISCONNECTS ARE NOT PROVIDED, TURN OFF POWER TO THE SIGN BY OTHER MEANS i.e. TURN OFF THE CIRCUIT BREAKER OR REMOVE THE FUSE AT THE SERVICE PANEL).

ATTENTION! METTRES HORS TENSION TOUS LES SECTIONNEURS INTEGRES AVANT D'ENTREPRENDRE LE DEPANNAGE

Attention!

ThinLED Constant Current (CC)

ThinLED CC is a low voltage, long life alternative to neon and florescent lighting for reverse channel letter illumination and edge lighting applications. The light source for ThinLED CC is the Light Emitting Diode (LED) instead of traditional neon or florescent tubes. LED technology allows ThinLED CC to provide excellent color and brightness in a safe, low voltage circuit (12 Volts DC). ThinLED CC is a robust, easily installed product designed for a long life of safe, maintenance free operation.

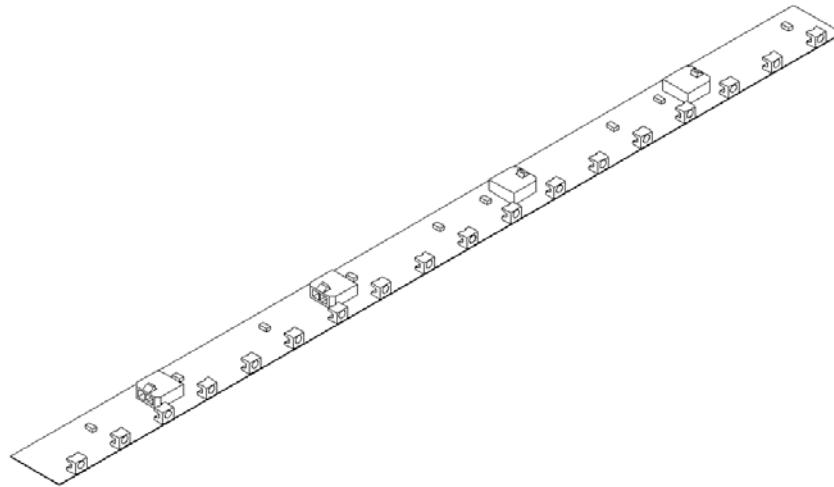

Figure 1 - ThinLED CC is made up of light strips 12" long, 3/4" wide, and 5/16" high. They can be cut to fit (cool colors can be cut in 1.33" increments, warm colors in 2" increments), and are daisy chained together with jumpers that have positive locking connectors. They are designed to mount to the return of the letter with the LEDs facing the wall on which the letters are to be mounted.

Tools Required

1. Wire stripper
2. Measuring Tape
3. Drill
4. Screw Driver

Standard Hardware and Supplies (UL listing may be required on certain items) (Supplies listed below may be purchased from SloanLED)

1. AWG # 18, 2 conductor, PVC jacketed, NEC type Power Limited Circuit Cable (PLCC) with UL Listing. (100' Roll is SloanLED part number 400299-1200)
2. AWG # 14, 2 conductors, PVC jacketed, NEC type Power Limited Circuit Cable (PLCC) with UL Listing. (100' Roll is SloanLED part number 400301)
3. 6" Jumper Wires (SloanLED PN 701655-B)
4. "Y" Connector (SloanLED PN 410115-B)
5. ThinLED CC Power Supply Hook-up kit (PN 701693)
6. 4" nylon zip ties.
7. Wire Nuts (IDEAL P/N #30-073 Orange) (SloanLED P/N 701573-10)
8. Outdoor rated caulk / Silicone sealant.
9. Conduit and J-Boxes as needed (Appropriate UL listing is required)
10. Disconnect switch for primary power shutoff if required by local/national Electrical Codes
11. UL Listed for wet location or NEMA 3R Box, min. dimensions 12" x 12" x 6", vented (if power supply is to be mounted in a location exposed to weather)

Populating the Channel Letter

ThinLED CC Layout

NOTE: These guidelines are an estimating tool. More or less product may be used in the actual population of the letters depending on scrap or illumination needs.

Select which channel letter returns will be populated with ThinLED CC, add up the linear distance of these returns and round up to the nearest full foot. This is approximately how many one-foot ThinLED CC strips will be needed to populate the letters.

Each one-foot strip has four connector headers. Any one of these headers can power the entire one-foot strip or be used to transfer power to another ThinLED CC section. Each one-foot strip can also be cut on any of the marked cut lines. As long as the cut section has a connector header on it, the section can be lit. Any small section that is trimmed off which does not have a connector header on it cannot be lit.

Items to consider:

Stroke Width- The stroke width of the letter and the illumination effect you are seeking will help you determine if you need to populate both returns of the reverse channel letter, or just one. Generally, if the stroke width is 2" or less, populating one side of the letter will provide adequate illumination. If the stroke width is wider than 2" or more illumination is desired, both sides can be populated.

Power routing- when laying out the ThinLED CC units, keep in mind that each unit will need a power hook up using a jumper. It is best to use as many full size 1' strips as possible to minimize the amount of jumpers required. One jumper is provided with each 1' strip of ThinLED CC and additional jumpers are available for purchase from SloanLED.

Placing ThinLED CC in a Channel Letter

1. Ensure bonding surface is clean and oil free.
2. Lay out ThinLED CC in letter housing for positioning and cut strips on cut marks as required.
3. Connect all jumper wires ensuring each strip is connected. Peel off tape backing and, pressing firmly, affix ThinLED CC strips into place.

Tight Bends/Mechanical Fastening

ThinLED CC is a very flexible product and can conform to bends as tight as 1" radius. However, very tight bends may put additional load on the mounting tape. In these situations, the installer may choose to use a mechanical fastener through one or more of the holes provided in the ThinLED CC strip, or use an appropriate epoxy along the edges and ends of the product for additional mounting security. When using screws to fasten ThinLED CC into place use a #6 pan or round head screw. Larger screws or flat head screws may damage the ThinLED CC strip. (Figure 2)

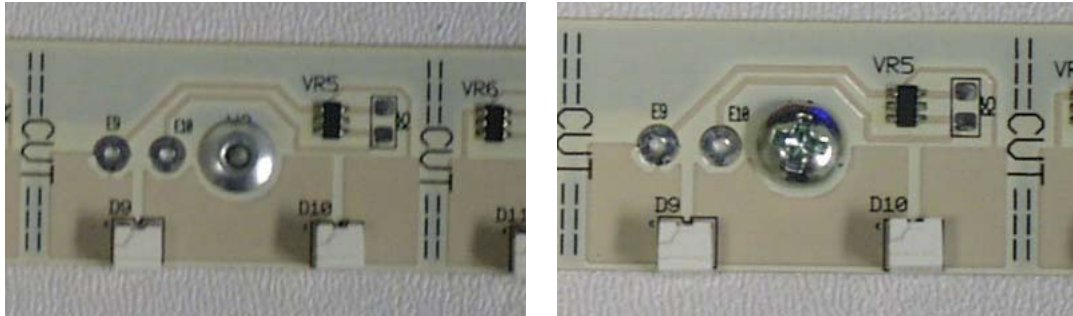

Figure 2 - Securing ThinLED CC using mechanical fasteners

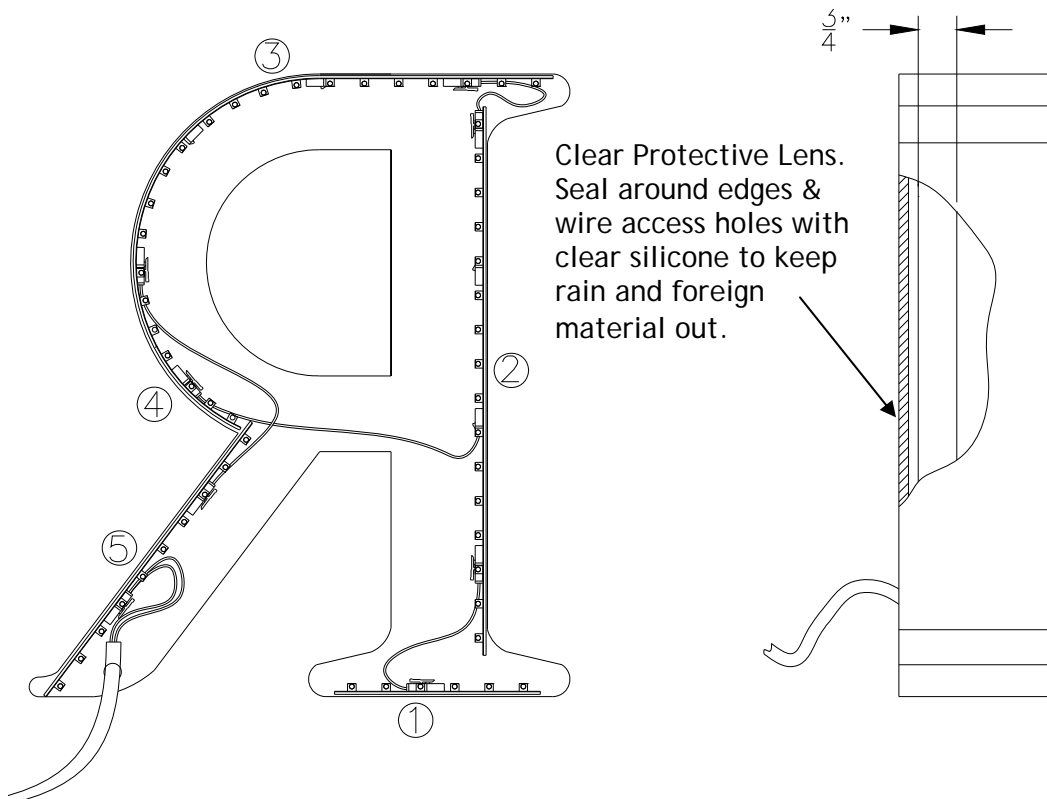

Figure 3 - Channel Letter for Reverse Illumination Populated with ThinLED CC.

Power Supply Connection

To connect ThinLED CC to power supply simply cut a ThinLED CC jumper in half, connect the black wire to the black wire on the power supply output lead, the red wire to the red wire on the power supply output lead, and then plug the connector into any available connector on your ThinLED daisy chain. (*NOTE: UL requires the wire nut connection to be located within the channel letter housing.*) ThinLED CC strips may be connected in series or parallel. After all connections have been made, replace the letter's lens. Seal edges and wire access holes with clear outdoor rated silicone to keep rain and foreign materials out of channel letter.

Power Supply Capacities:

Power Supply	Part # (Each)	Power Output	Maximum Number of Feet (Meters)
			ThinLED CC (all colors)
Self Contained 20	701680	20 Watts	8 (2.5)
Modular 60	701507-MOD	60 Watts	25 (7.5)
Modular 60-277	701507-MOD277	60 Watts	25 (7.5)
Quad 240*	701494	240 Watts	100 (30.5)
Power Used per Foot (Meter) in Watts			2.2 (7.2)

*Quad 240 has four output legs; footages expressed are total (divide by four for footage per leg)

It is recommended that the current be checked on each power supply output after loading is complete. The current drawn by each leg should not exceed the current rating on the power supply label. If the measured current does exceed the rated current, reduce the length of ThinLED on that leg until the current is below the rated output.

NOTE: If any power supply output leads are left unused, the two wires in the PLCC lead must be left individually capped with wire nuts inside a UL Listed junction box, race way or sign housing.

Routing Secondary Wires

When wiring the secondary outputs of the power supply, all routing through walls must be sealed with outdoor rated caulk to protect the sign and building from water damage and the cable from chafing. The PLCC used for power supply leads and jumpers can be routed through walls, inside and outside without conduit. It is recommended that all connections be enclosed inside the channel letter or a UL listed junction box with strain relief.

Extension of Power Supply Leads

If a longer lead wire from the power supply to ThinLED chain is needed, an extension can be used. The extension should be kept as short as possible (under 15 feet for 18 AWG UL Listed PLCC or under 50 feet for 14 AWG UL Listed PLCC).

WARNING: CHECK POLARITY:

After all wire routing is complete and the lighting modules are connected to the power supply, RECHECK THE POLARITY OF ALL CONNECTIONS. They must be RED TO RED AND BLACK TO BLACK throughout the entire system. Reverse polarity connections may damage the LEDs and void the product warranty.

Note: For power supply installation instructions check the manual packaged with your power supply or check online at www.SloanLED.com

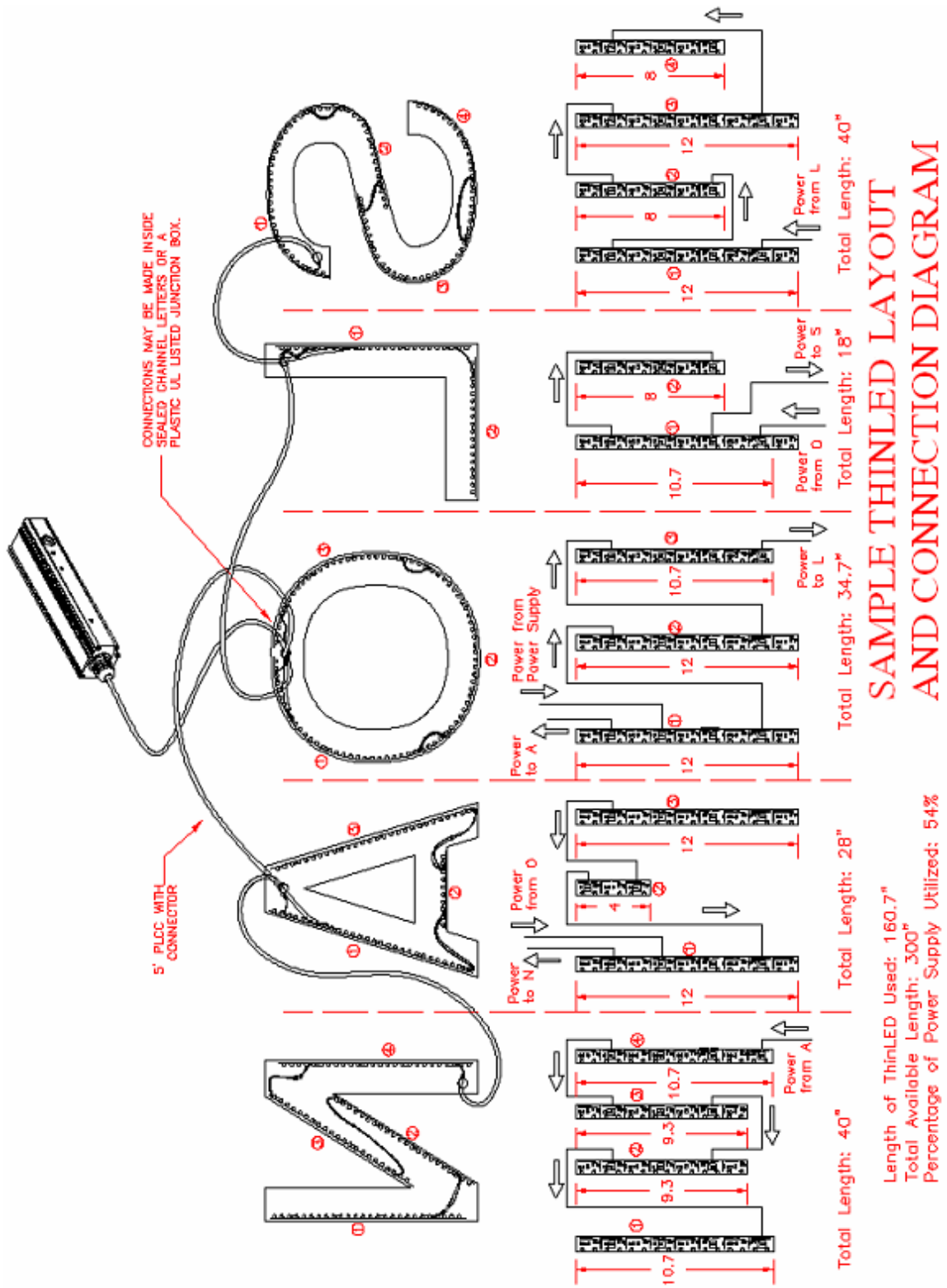

Figure 4 - Sample Layout and Connection Diagram

Making a Custom Length Letter-to-Letter Jumper

To make a custom length letter to letter jumper you will need (1) 6" jumper, (1) UL listed PVC jacketed, 18 AWG, 2 conductor power limited circuit cable long enough to make the letter-to-letter connection, (4) wire nuts, (2) 4" nylon zip ties and a wire stripper.

NOTE: UL requires the wire nut connection to be located within the channel letter housing.

1. Strip the ends of the cable as shown in Figure 5.
2. Cut the 6" jumper in the middle and strip the ends of each wire as shown in Figure 5.
3. Using the wire nuts, connect one connector assembly to each end of the cable. Connect black wire to black wire and red wire to red wire.
4. Use the zip ties to create a strain relief as shown in Figure 6.

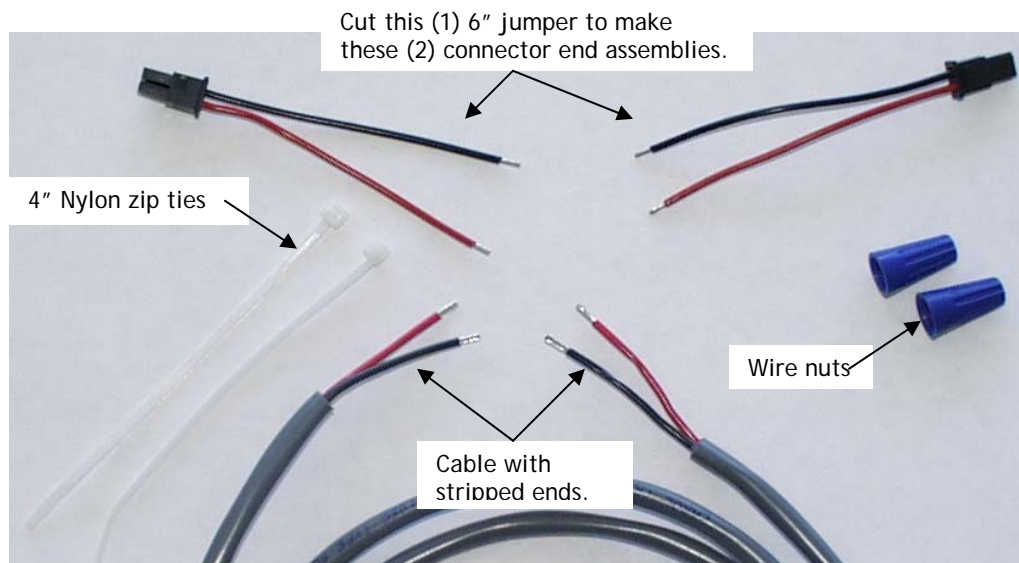

Figure 5 - Items needed for Letter-to-Letter Jumper.



Figure 6 - Completed Letter-to-Letter Jumper.

Troubleshooting Guide

Entire Sign or leg with ThinLED CC does not light after complete installation.

-Check the connection from the power supply lead to the first ThinLED CC unit. Make sure the polarity of the connections made at the power supply lead and any jumper wires is correct. Power supply outputs to the gray cable should be red-to-red and black-to-black. Connecting a grey cable to a 6" jumper should be red-to-red and black-to-black.

Still does not light.

-Using a voltmeter check the output voltage of the power supply. The output voltage should be $12.0 \pm 0.5\text{VDC}$. If there is no output voltage, have a licensed electrician check input voltage and make sure the power supply is hooked up correctly and getting primary power. If the power supply is hooked up correctly and getting primary power and there is still no output voltage, replace the power supply with a new one.

ThinLED CC goes dim after a short time of operation.

The primary cause of ThinLED CC going dim after a short period of operation is too much current draw on the power supply leg. First, check the current draw on the leg or legs that go dim. Ensure the current draw is less than the maximum output current marked on the power supply label. If all units are wired as recommended, the current draw will be below these levels. To correct the dimming problems reduce the number of ThinLED CC strips on each leg until the current draw is below the rated current for the power supply.

The beginning of a ThinLED CC leg lights, but the entire leg does not light or lights intermittently.

The primary cause of part of a ThinLED CC leg not lighting or lighting intermittently is a bad connection at the connector between the units that light and the units that don't light. Check this connection. Look for wires pulling out of the connector or broken at the back of the connector housing. If the wires are pulling out of the connector housing, disconnect the connector, reseal the wire in the housing and reconnect. If the wire is broken or will not reseal, replace the jumper with a new one.

One ThinLED CC strip or section does not light, but all others in the leg light.

ThinLED CC is designed so if one section goes out, it will not cause the entire sign or leg to go out. If one ThinLED CC section is not lighting, but all others in the leg are lighting, replace the section or strip with a new one. If replacing a section, ensure new section and any remaining sections have a connector to plug into. The unit cannot be repaired in the field.